



**Reductores sinfín - corona**  
**Serie TRV / TMRV**

**TEKMATIC**

## Características

La serie de reductores y motorreductores TRV / TMRV a sinfín-corona son una nueva generación de productos desarrollados por el mayor fabricante de reductores de la República Popular de China, el cual le provee a las principales marcas Europeas. De ahí que su intercambiabilidad con los equipos italianos y alemanes está asegurada.

La relación costo beneficio de estos equipos los hace la mejor elección a la hora de equipar sus máquinas.

### Algunas de sus principales características son:

Fabricados con aleación de aluminio inyectado de alta calidad, otorgando bajo peso y gran rigidez estructural.

Alta capacidad de disipación térmica.

Torque de salida superior.

Trabajo sereno y silencioso gracias a su sinfín cementado, con dientes rectificadas, montado sobre rodamientos de primera calidad.

Corona de bronce de ancho superior para garantizar su durabilidad.

Sellados con retenes de doble labio y anillos O'ring.

Lubricados con aceite sintético, con tapones de carga y descarga.

Intercambiabilidad asegurada con los principales reductores del tipo "block".

Brida de entrada norma IEC para motores B5 y B14.

## Selección

### Símbolos

$f_s$ : factor de servicio

$i$ : relación de transmisión

$M_{n2}$ : torque nominal a la salida del reductor [Nm]

$M_{c2}$ : torque de cálculo a la salida del reductor [Nm]

$M_{r2}$ : torque requerido a la salida del reductor [Nm]

$n_1$ : velocidad angular del eje de entrada [ $\text{min}^{-1}$ ]

$n_2$ : velocidad angular del eje de salida [ $\text{min}^{-1}$ ]

$P_1$ : potencia a la entrada del reductor [kW]

$P_2$ : potencia a la salida del reductor [kW]

$S$ : factor de seguridad

$\eta$ : rendimiento dinámico del reductor

## Factor de servicio

Es el factor que toma en consideración, con suficiente aproximación, la variabilidad de las cargas y los eventuales choques a los que se verá sometido el reductor para un determinado tipo de servicio.

A continuación se tabulan los valores  $f_s$  para aplicaciones típicas y diferentes regímenes de uso.

Factor de servicio - $f_s$											
Tipo de servicio	horas al día	N° arranques/hora									Aplicaciones típicas
		2	4	8	16	32	63	125	250	500	
Carga uniforme	4	0,85	0,90	0,90	0,93	0,98	1,03	1,06	1,10	1,20	Agitadores para líquidos puros Alimentadores para calderas Alimentadores de disco Filtros de lavado con aire Generadores Bombas centrífugas Transportadores con carga uniforme
	8	1,00	1,00	1,10	1,10	1,15	1,20	1,24	1,30	1,30	
	16	1,20	1,20	1,25	1,30	1,35	1,45	1,50	1,50	1,55	
	24	1,40	1,40	1,45	1,50	1,55	1,60	1,65	1,70	1,75	
Carga con choques moderados	4	1,11	1,12	1,15	1,19	1,23	1,28	1,32	1,36	1,40	Agitadores para líquidos y sólidos Alimentadores de cinta Montacargas con servicio medio Filtros con piedras y grava Tornillos para expulsión de agua Floculadores Elevadores de cangilones Grúas
	8	1,29	1,31	1,34	1,40	1,45	1,51	1,56	1,60	1,64	
	16	1,54	1,56	1,59	1,65	1,71	1,78	1,84	1,90	1,96	
	24	1,73	1,75	1,80	1,90	1,97	2,05	2,10	2,16	2,22	
Carga con choques fuertes	4	1,46	1,46	1,48	1,51	1,57	1,61	1,62	1,64	1,66	Montacargas para servicio pesado Extrusores Rejillas para goma Prensas para ladrillos Cepilladoras Molinos de bola
	8	1,71	1,71	1,73	1,76	1,82	1,86	1,87	1,89	1,89	
	16	2,04	2,05	2,07	2,10	2,15	2,20	2,21	2,23	2,23	
	24	2,31	2,31	2,33	2,36	2,42	2,48	2,52	2,54	2,56	

## Pasos para la selección

### Motorreductor (serie TMRV)

- 1- Determinar el factor de servicio  $f_s$
- 2- Obtener el torque de cálculo  $M_{c2}$  para la aplicación

$$M_{c2} = M_{r2} \times f_s$$

ó

$$M_{c2} = (9550 \times P_2 \times f_s) / n_2$$

- 3- Conociendo  $M_{c2}$  y  $n_2$ , seleccionar de las tablas de producto el motorreductor que proporcione un torque nominal  $M_2 > M_{c2}$  a la velocidad más cercana a la requerida y que posea un factor de seguridad  $S$  mayor o igual al factor de servicio  $f_s$  calculado en el punto 1.

$$S \geq f_s$$

- 4- Realizar las verificaciones correspondientes.

*Nota: utilizar la capacidad de carga informada en las tablas correspondientes a los reductores*

### Reductor (serie TRV)

- 1- Determinar el factor de servicio  $f_s$
- 2- Obtener el torque de cálculo  $M_{c2}$  para la aplicación

$$M_{c2} = M_{r2} \times f_s$$

ó

$$M_{c2} = (9550 \times P_2 \times f_s) / n_2$$

- 3- En base a la velocidad de salida requerida  $n_2$  y aquella disponible a la entrada  $n_1$ , calcular la relación de transmisión

$$i = n_1 / n_2$$

- 4- Conociendo  $M_{c2}$  e  $i$ , seleccionar de las tablas de producto el reductor que proporcione un torque nominal  $M_{n2} > M_{c2}$  con la relación más cercana a la requerida
- 5- Obtener la potencia  $P_1$  requerida a la entrada en función del rendimiento del reductor seleccionado

$$P_1 = P_2 / \eta$$

- 6- Realizar las verificaciones correspondientes.

## Verificaciones

Una vez seleccionado el reductor o motorreductor se recomienda realizar las siguientes verificaciones:

### 1- Torque máximo

El torque máximo (entendido como valor pico instantáneo) aplicable al reductor no debe superar el 200% del torque nominal  $M_{n2}$ . Por lo tanto verificar que no se exceda este límite, adoptando algún dispositivo limitador de torque en caso de ser necesario.

Para motores trifásicos de doble polaridad, se debe prestar especial atención al torque instantáneo generado en la conmutación de la alta velocidad a la baja, ya que puede ser significativamente mayor al torque máximo admitido.

Un método simple y económico para reducir este torque es alimentar solo dos fases durante la conmutación (el tiempo de alimentación bifásica puede regularse con un relé temporizador):

$$M_{g2} = 0,5 \times M_{g3}$$

$M_{g2}$ : Torque de conmutación alimentando a 2 fases

$M_{g3}$ : Torque de conmutación alimentando a 3 fases

### 2- Cargas radiales

Verificar que las cargas radiales sobre los ejes de entrada y salida se encuentran dentro los valores permitidos en el catálogo. Si resultan superiores, aumentar el tamaño del reductor, o modificar la configuración de los apoyos.

$$F_{c1-2} \leq F_{1-2}$$

$$F_{c1-2} = (2000 \times M_{1-2} \times K_r) / d$$

$F_{c1-2}$ : carga radial de cálculo en eje de entrada-salida [N]

$M_{1-2}$ : torque transmitido [Nm]

$d$ : diámetro primitivo de cadena, engranaje, correa, etc [mm]

$K_r=1$ : cadena

$K_r=1,25$ : engranaje

$K_r=1,5$ : correa dentada

$K_r=2,5$ : correa en V

Los valores  $F_{1-2}$  tabulados corresponden a una carga radial centrada en la longitud en voladizo (B). Si actúa a  $0,3 \times B$  del resalte, multiplicarla por 1,25; si actúa a  $0,8 \times B$  multiplicarla por 0,8.

### 3- Cargas axiales

Se permite una carga axial de hasta 0,2 veces  $F_{1-2}$  simultáneamente con la carga radial.

# Características dimensionales

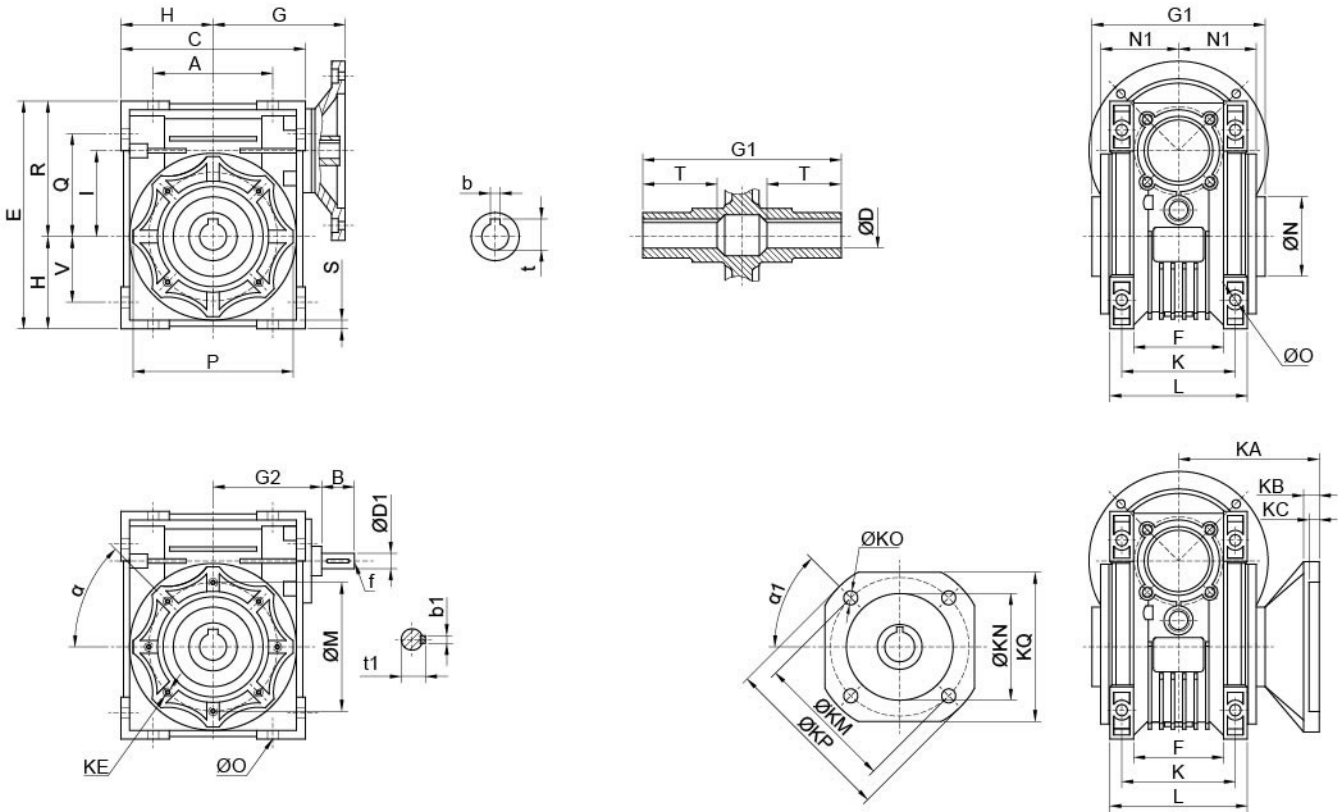

Tamaño	A	B	C	D H7	D1 J6	E	F	G	G1	G2	H	I	L	M	N h8	N1	O	P	Q	R
30	54	20	80	14	9	97	32	55	63	51	40	30	56	65	55	29	6,5	75	44	57
40	70	23	100	18 (19)	11	121,5	43	70	78	60	50	40	71	75	60	36,5	6,5	87	55	71,5
50	80	30	120	25 (24)	14	144	49	80	92	74	60	50	85	85	70	43,5	8,5	100	64	84
63	100	40	144	25 (28)	19	174	67	95	112	90	72	63	103	95	80	53	8,5	110	80	102
75	120	50	172	28 (35)	24	205	72	112,5	120	105	86	75	112	115	95	57	11	140	93	119
90	140	50	208	35 (38)	24	238	74	129,5	140	125	103	90	130	130	110	67	13	160	102	135
110	170	60	252,5	42	28	295	---	160	155	142	127,5	110	144	165	130	74	14	200	125	167,5
130	200	80	292,5	45	30	335	---	180	170	162	147,5	130	155	215	180	81	16	250	140	187,5
150	240	80	340	50	35	400	---	210	200	192	170	150	185	215	180	96	18	250	180	230

Tamaño	S	T	V	K	KA			KB			KC			KE	α	α1	KM		
					F	FB	FL	F	FB	FL	F	FB	FL				F	FB	FL
30	5,5	21	27	44	54,5	---	---	6	---	---	4	---	---	M6x11 (n4)	0	45	68	---	---
40	6,5	26	35	60	67	76,5	97	7	9	7	4	5	4	M6x8 (n4)	45	45	87	115	87
50	7	30	40	70	90	87,5	120	9	10	9	5	5	5	M8x10 (n4)	45	45	90	130	90
63	8	36	50	85	82	99	112	10	11	10	6	5	6	M8x14 (n8)	45	45	150	165	150
75	10	40	60	90	111	---	---	13	---	---	6	---	---	M8x14 (n8)	45	45	165	---	---
90	11	45	70	100	111	---	---	13	---	---	6	---	---	M10x18 (n8)	45	45	175	---	---
110	14	50	85	115	131	---	---	15	---	---	6	---	---	M10x18 (n8)	45	45	230	---	---
130	15	60	100	120	140	---	---	15	---	---	6	---	---	M12x21 (n8)	45	22,5	255	---	---
150	18	72,5	120	145	155	---	---	15	---	---	6	---	---	M12x21 (n8)	45	22,5	255	---	---

Tamaño	KN (H8)			KO			KP			KQ			b	t	b1	t1	f	kg
	F	FB	FL	F	FB	FL	F	FB	FL	F	FB	FL						
30	50	---	---	6,5(n4)	---	---	80	---	---	70	---	---	5	16,3	3	10,2	---	1,2
40	60	95	60	9(n4)	9,5(n4)	9(n4)	110	140	110	95	---	95	6	20,8 (21,8)	4	12,5	---	2,3
50	70	110	70	11(n4)	9,5(n4)	11(n4)	125	160	125	110	---	110	8	28,3 (27,3)	5	16	M6	3,5
63	115	130	115	11(n4)	11(n4)	11(n4)	180	200	180	142	---	142	8	28,3 (31,3)	6	21,5	M6	6,2
75	130	---	---	14(n4)	---	---	200	---	---	170	---	---	8 (10)	31,3 (38,3)	8	27	M8	9
90	152	---	---	14(n4)	---	---	210	---	---	200	---	---	10	38,3 (41,3)	8	27	M8	13
110	170	---	---	14(n8)	---	---	280	---	---	260	---	---	12	45,3	8	31	M10	35
130	180	---	---	16(n8)	---	---	320	---	---	290	---	---	14	48,8	8	33	M10	48
150	180	---	---	16(n8)	---	---	320	---	---	290	---	---	14	53,8	10	38	M12	84

Características dimensionales bridas B5

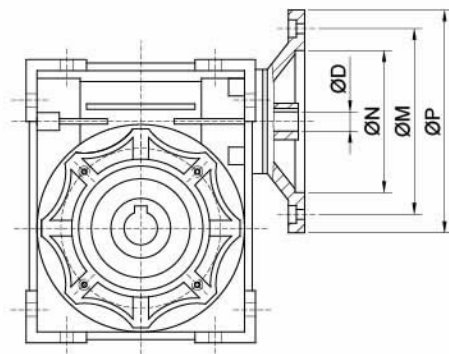

Tamaño	PAM IEC	N	M	P	D										
					7,5	10	15	20	25	30	40	50	60	80	100
30	63B5	95	115	140	11	11	11	11	11	11	11	11	---	---	---
	63B14	60	75	90	---	---	---	---	---	---	---	---	---	---	---
	56B5	80	100	120	9	9	9	9	9	9	9	9	9	9	---
	56B14	50	65	80	---	---	---	---	---	---	---	---	---	---	---
40	71B5	110	130	160	14	14	14	14	14	14	14	---	---	---	---
	71B14	70	85	105	---	---	---	---	---	---	---	---	---	---	---
	63B5	95	115	140	11	11	11	11	11	11	11	11	11	11	11
	63B14	60	75	90	---	---	---	---	---	---	---	---	---	---	---
50	56B5	80	100	120	---	---	---	---	---	---	---	9	9	9	9
	80B5	130	165	200	19	19	19	19	19	19	---	---	---	---	---
	80B14	80	100	120	---	---	---	---	---	---	---	---	---	---	---
	71B5	110	130	160	14	14	14	14	14	14	14	14	14	14	---
63	71B14	70	85	105	---	---	---	---	---	---	---	14	14	14	14
	63B5	95	115	140	---	---	---	---	---	---	11	11	11	11	11
	90B5	130	165	200	24	24	24	24	24	24	---	---	---	---	---
	90B14	95	115	140	---	---	---	---	---	---	---	---	---	---	---
	80B5	130	165	200	19	19	19	19	19	19	19	19	19	19	19
	80B14	80	100	120	---	---	---	---	---	---	---	---	---	---	---
75	71B5	110	130	160	---	---	---	---	---	---	14	14	14	14	14
	71B14	70	85	105	---	---	---	---	---	---	---	---	---	---	---
	100/112B5	180	215	250	28	28	28	---	---	---	---	---	---	---	---
	100/112B14	110	130	160	---	---	---	---	---	---	---	---	---	---	---
	90B5	130	165	200	24	24	24	24	24	24	24	24	24	24	24
	90B14	95	115	140	---	---	---	---	---	---	---	---	---	---	---
90	80B5	130	165	200	---	---	---	---	---	---	19	19	19	19	19
	80B14	80	100	120	---	---	---	---	---	---	---	---	---	---	---
	100/112B5	180	215	250	28	28	28	28	28	28	---	---	---	---	---
	100/112B14	110	130	160	---	---	---	---	---	---	---	---	---	---	---
	90B5	130	165	200	24	24	24	24	24	24	24	24	24	24	24
	90B14	95	115	140	---	---	---	---	---	---	---	---	---	---	---
110	80B5	130	165	200	---	---	---	---	---	---	19	19	19	19	19
	132B5	230	265	300	38	38	38	38	38	38	38	38	38	38	38
	100/112B5	180	215	250	28	28	28	28	28	28	28	28	28	28	28
130	90B5	130	165	200	---	---	---	---	---	---	---	---	---	24	24
	132B5	230	265	300	38	38	38	38	38	38	38	38	38	38	38
150	160B5	250	300	350	42	42	42	42	---	---	---	---	---	---	---
	132B5	230	265	300	---	---	---	38	38	38	38	38	38	38	38
	100/112B5	180	210	250	---	---	---	---	---	---	---	28	28	28	28

Características dimensionales doble eje del sinfín

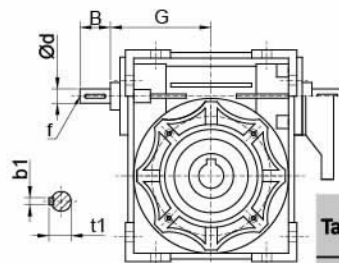

Tamaño	G	d (j6)	B	f	b1	t1
30	45	9	20	---	3	10,2
40	53	11	23	---	4	12,5
50	64	14	30	M6	5	16
63	75	19	40	M6	6	21,5
75	90	24	50	M8	8	27
90	108	24	50	M8	8	27
110	135	28	60	M10	8	31
130	155	30	80	M10	8	33
150	175	35	80	M12	10	38

Características dimensionales brazo de reacción

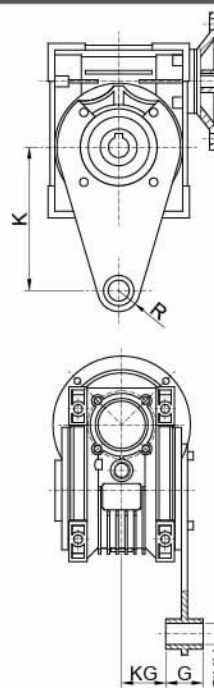

Tamaño	K	G	KG	KH	R
30	85	14	24	8	15
40	100	14	31,5	10	18
50	100	14	38,5	10	18
63	150	14	49	10	18
75	200	25	47,5	20	30
90	200	25	57,5	20	30
110	250	30	62	25	35
130	250	30	69	25	35
150	250	30	84	25	35

Características dimensionales eje de salida

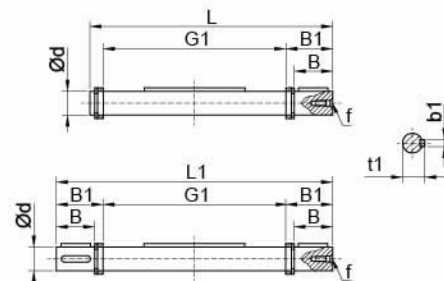

Tamaño	d (h6)	b1	t1	L	L1	G1	B	B1	f
30	14	5	16	102	128	63	30	32,5	M6
40	18	6	20,5	128	164	78	40	43	M6
50	25	8	28	153	199	92	50	53,5	M10
63	25	8	28	173	219	112	50	53,5	M10
75	28	8	31	192	247	120	60	63,5	M10
90	35	10	38	234	309	140	80	84,5	M12
110	42	12	45	249	324	155	80	84,5	M16
130	45	14	48,5	265	340	170	80	85	M16
150	50	14	53,5	297	374	200	82	87	M16

i	n2 (v/min)	TMRV 30								TMRV 40											
		0,06 kW 0,08 hp (56A)		0,09 kW 0,12 hp (56B)		0,12 kW 0,16 hp (63A)		0,18 kW 0,25 hp (63B)		0,12 kW 0,16 hp (63A)		0,18 kW 0,25 hp (63B)		0,25 kW 0,34 hp (71A)		0,37 kW 0,5 hp (71B)		0,55 kW 0,75 hp (80A)			
		Mn2 (Nm)	S P/P1	Mn2 (Nm)	S P/P1	Mn2 (Nm)	S P/P1	Mn2 (Nm)	S P/P1	Mn2 (Nm)	S P/P1	Mn2 (Nm)	S P/P1	Mn2 (Nm)	S P/P1	Mn2 (Nm)	S P/P1	Mn2 (Nm)	S P/P1	Mn2 (Nm)	S P/P1
7,5	186,7	2,6	6,8	3,9	4,6	5,2	3,4	8,0	2,3	5,3	7,5	8,0	5,0	11,0	3,6	16,0	2,4	24,5	1,6		
10	140,0	3,4	5,3	5,0	3,6	6,7	2,7	10,0	1,8	7,0	5,8	10,0	3,8	14,0	2,8	21,0	1,9	32,0	1,3		
15	93,3	4,7	3,8	7,1	2,6	9,5	1,9	14,0	1,3	10,1	4,0	15,0	2,7	20,0	1,9	30,0	1,3	---	---		
20	70,0	6,0	3,0	9,0	2,0	12,0	1,5	18,0	1,0	12,8	3,1	19,0	2,1	26,0	1,5	39,0	1,0	---	---		
25	56,0	7,0	3,0	10,4	2,0	13,9	1,5	20,0	1,0	15,3	2,5	23,0	1,7	31,0	1,2	---	---	---	---		
30	46,7	8,0	2,5	12,0	1,7	16,0	1,3	---	---	17,2	2,6	26,0	1,7	36,0	1,2	---	---	---	---		
40	35,0	9,7	1,8	14,5	1,2	17,0	0,9	---	---	21,3	1,9	32,0	1,3	44,0	0,9	---	---	---	---		
50	28,0	11,3	1,5	16,9	1,0	---	---	---	---	25,4	1,5	38,0	1,0	---	---	---	---	---	---		
60	23,3	12,5	1,3	16,9	0,9	---	---	---	---	28,5	1,3	---	---	---	---	---	---	---	---		
80	17,5	12,5	0,8	---	---	---	---	---	---	34,1	1,0	---	---	---	---	---	---	---	---		
100	14,0	---	---	---	---	---	---	---	---	---	---	---	---	---	---	---	---	---	---		

i	n2 (v/min)	TMRV 50										TMRV 63													
		0,12 kW 0,16 hp (63A)		0,18 kW 0,25 hp (63B)		0,25 kW 0,34 hp (71A)		0,37 kW 0,5 hp (71B)		0,55 kW 0,75 hp (80A)		0,75 kW 1,0 hp (80B)		0,25 kW 0,34 hp (71A)		0,37 kW 0,5 hp (71B)		0,55 kW 0,75 hp (80A)		0,75 kW 1,0 hp (80B)		1,1 kW 1,5 hp (90S)			
		Mn2 (Nm)	S P/P1	Mn2 (Nm)	S P/P1	Mn2 (Nm)	S P/P1	Mn2 (Nm)	S P/P1	Mn2 (Nm)	S P/P1	Mn2 (Nm)	S P/P1	Mn2 (Nm)	S P/P1	Mn2 (Nm)	S P/P1	Mn2 (Nm)	S P/P1	Mn2 (Nm)	S P/P1	Mn2 (Nm)	S P/P1	Mn2 (Nm)	S P/P1
7,5	186,7	---	---	---	---	11,0	6,4	16,0	4,3	25,0	2,9	34,0	2,1	---	---	---	---	---	---	33	3,7	49	2,5		
10	140,0	---	---	---	---	14,0	4,8	21,0	3,2	32,0	2,2	44,0	1,6	---	---	---	---	---	---	44	2,9	65	2,0		
15	93,3	---	---	---	---	21,0	3,5	31,0	2,4	46,0	1,6	63,0	1,2	---	---	---	---	46	2,9	63	2,1	93	1,5		
20	70,0	---	---	---	---	26,0	2,7	39,0	1,8	59,0	1,2	---	---	---	---	---	---	60	2,2	82	1,6	121	1,1		
25	56,0	---	---	---	---	32,0	2,2	47,0	1,5	---	---	---	---	---	---	---	---	72	1,8	99	1,3	---	---		
30	46,7	---	---	---	---	36,0	2,3	54,0	1,5	---	---	---	---	---	---	---	---	80	2,0	109	1,5	---	---		
40	35,0	21,9	---	---	---	45,0	1,7	66,0	1,1	---	---	---	---	---	---	70	2,1	104	1,4	143	1,0	---	---		
50	28,0	25,8	2,8	38,0	1,9	53,0	1,4	73,0	0,9	---	---	---	---	---	---	83	1,6	123	1,1	---	---	---	---		
60	23,3	29,0	2,3	34,0	1,6	60,0	1,1	---	---	---	---	---	---	---	---	95	1,4	---	---	---	---	---	---		
80	17,5	34,7	1,8	53,0	1,2	65,0	0,9	---	---	---	---	---	---	77	1,6	114	1,1	---	---	---	---	---	---		
100	14,0	40,1	1,3	55,0	0,9	---	---	---	---	---	---	---	---	85	1,4	118	0,9	---	---	---	---	---	---		

i	n2 (v/min)	TMRV 75								TMRV 90							
		0,55 kW 0,75 hp (80A)		0,75 kW 1,0 hp (80B)		1,1 kW 1,5 hp (90S)		1,5 kW 2,0 hp (90LA)		0,75 kW 1,0 hp (80B)		1,1 kW 1,5 hp (90S)		1,5 kW 2,0 hp (90LA)		2,2 kW 3,0 hp (100LA)	
		Mn2 (Nm)	S P/P1	Mn2 (Nm)	S P/P1	Mn2 (Nm)	S P/P1	Mn2 (Nm)	S P/P1	Mn2 (Nm)	S P/P1	Mn2 (Nm)	S P/P1	Mn2 (Nm)	S P/P1	Mn2 (Nm)	S P/P1
7,5	186,7	---	---	---	---	49	3,7	67	2,7	---	---	---	---	---	---	101	2,9
10	140,0	---	---	---	---	66	2,9	90	2,1	---	---	---	---	---	---	133	2,3
15	93,3	---	---	---	---	95	2,1	130	1,5	---	---	---	---	---	---	193	1,9
20	70,0	---	---	---	---	122	1,7	167	1,3	---	---	---	---	---	---	251	1,4
25	56,0	---	---	---	---	149	1,4	200	1,0	---	---	---	---	209	1,6	307	1,1
30	46,7	---	---	116	2,0	170	1,4	230	1,0	---	---	---	---	236	1,7	346	1,2
40	35,0	108	2,0	147	1,5	216	1,0	---	---	---	---	225	1,6	306	1,2	---	---
50	28,0	129	1,6	176	1,2	---	---	---	---	184	1,9	271	1,3	369	0,9	---	---
60	23,3	146	1,4	200	1,0	---	---	---	---	212	1,5	311	1,0	---	---	---	---
80	17,5	180	1,1	---	---	---	---	---	---	257	1,1	---	---	---	---	---	---
100	14,0	180	0,9	---	---	---	---	---	---	270	0,9	---	---	---	---	---	---

i	n2 (v/min)	TMRV 110													
		1,1 kW 1,5 hp (90S)		1,5 kW 2,0 hp (90LA)		2,2 kW 3,0 hp (100LA)		3 kW 4,0 hp (100LB)		4 kW 5,5 hp (112M)		5,5 kW 7,5 hp (132S)		7,5 kW 10 hp (132MA)	
		Mn2 (Nm)	S P/P1	Mn2 (Nm)	S P/P1	Mn2 (Nm)	S P/P1	Mn2 (Nm)	S P/P1	Mn2 (Nm)	S P/P1	Mn2 (Nm)	S P/P1	Mn2 (Nm)	S P/P1
7,5	186,7	---	---	---	---	101	5,5	138	4,0	184	3,0	253	2,2	345	1,6
10	140,0	---	---	---	---	133	4,5	182	3,3	243	2,5	334	1,8	455	1,3
15	93,3	---	---	---	---	193	3,4	263	2,5	352	1,9	484	1,4	---	---
20	70,0	---	---	---	---	256	2,5	348	1,9	464	1,4	---	---	---	---
25	56,0	---	---	---	---	316	2,1	430	1,6	573	1,2	---	---	---	---
30	46,7	---	---	---	---	355	2,0	484	1,5	646	1,1	---	---	---	---
40	35,0	---	---	---	---	462	1,5	631	1,1	---	---	---	---	---	---
50	28,0	---	---	375	1,7	550	1,2	---	---	---	---	---	---	---	---
60	23,3	324	1,9	442	1,4	---	---	---	---	---	---	---	---	---	---
80	17,5	410	1,3	490	0,9	---	---	---	---	---	---	---	---	---	---
100	14,0	460	1,0	---	---	---	---	---	---	---	---	---	---	---	---

i	n2 (v/min)	TMRV 130									
		2,2 kW 3,0 hp (100LA)		3 kW 4,0 hp (100LB)		4 kW 5,5 hp (112M)		5,5 kW 7,5 hp (132S)		7,5 kW 10 hp (132MA)	
		Mn2 (Nm)	S P/P1	Mn2 (Nm)	S P/P1	Mn2 (Nm)	S P/P1	Mn2 (Nm)	S P/P1	Mn2 (Nm)	S P/P1
7,5	186,7	---	---	---	---	186	4,0	256	2,9	349	2,1
10	140,0	---	---	---	---	243	3,4	334	2,5	455	1,8
15	93,3	---	---	---	---	357	2,6	490	1,9	667	1,4
20	70,0	---	---	---	---	466	2,0	645	1,4	---	---
25	56,0	---	---	---	---	573	1,6	788	1,2	---	---
30	46,7	---	---	---	---	655	1,6	900	1,2	---	---
40	35,0	---	---	638	1,6	850	1,2	---	---	---	---
50	28,0	566	1,7	767	1,3	1023	1,0	---	---	---	---
60	23,3	650	1,4	884	1,0	---	---	---	---	---	---
80	17,5	803	1,0	---	---	---	---	---	---	---	---
100	14,0	---	---	---	---	---	---	---	---	---	---

i	n2 (v/min)	TMRV 150													
		2,2 kW 3,0 hp (100LA)		3 kW 4,0 hp (100LB)		4 kW 5,5 hp (112M)		5,5 kW 7,5 hp (132S)		7,5 kW 10 hp (132MA)		11 kW 15 hp (160M)		15 kW 20 hp (160L)	
		Mn2 (Nm)	S P/P1	Mn2 (Nm)	S P/P1	Mn2 (Nm)	S P/P1	Mn2 (Nm)	S P/P1	Mn2 (Nm)	S P/P1	Mn2 (Nm)	S P/P1	Mn2 (Nm)	S P/P1
7,5	186,7	---	---	---	---	---	---	---	---	---	---	512	2,3	698	1,7
10	140,0	---	---	---	---	---	---	---	---	---	---	675	1,8	921	1,3
15	93,3	---	---	---	---	---	---	---	---	---	---	990	1,2	---	---
20	70,0	---	---	---	---	---	---	645	1,9	880	1,4	---	---	---	---
25	56,0	---	---	---	---	---	---	788	1,6	1074	1,2	---	---	---	---
30	46,7	---	---	---	---	---	---	934	1,3	---	---	---	---	---	---
40	35,0	---	---	---	---	---	---	1171	1,3	---	---	---	---	---	---
50	28,0	570	2,5	778	1,8	1037	1,4	---	---	---	---	---	---	---	---
60	23,3	657	2,0	896	1,5	1195	1,1	---	---	---	---	---	---	---	---
80	17,5	816	1,5	1110	1,1	---	---	---	---	---	---	---	---	---	---
100	14,0	960	1,1	---	---	---	---	---	---	---	---	---	---	---	---

i	n2 (v/min)	TRV 30					TRV 40					TRV 50				
		Mn2 (Nm)	P (kW)	$\eta$	F1 (N)	F2 (N)	Mn2 (Nm)	P (kW)	$\eta$	F1 (N)	F2 (N)	Mn2 (Nm)	P (kW)	$\eta$	F1 (N)	F2 (N)
7,5	186,7	18	0,41	0,86	150	683	40	0,90	0,87	294	1315	71	1,60	0,87	401	1805
10	140,0	18	0,32	0,82	169	752	40	0,69	0,85	331	1447	72	1,20	0,88	490	1987
15	93,3	18	0,23	0,76	169	861	40	0,48	0,81	331	1657	74	0,88	0,82	490	2274
20	70,0	18	0,18	0,73	190	948	39	0,37	0,77	350	1824	73	0,68	0,79	490	2503
25	56,0	21	0,18	0,68	210	1021	38	0,30	0,74	350	1964	70	0,54	0,76	490	2696
30	46,7	20	0,15	0,65	210	1085	45	0,31	0,71	350	2087	84	0,57	0,72	490	2865
40	35,0	18	0,11	0,60	210	1194	41	0,23	0,65	350	2298	76	0,42	0,66	490	3153
50	28,0	17	0,09	0,55	210	1286	39	0,18	0,64	350	2475	73	0,34	0,63	490	3397
60	23,3	16	0,08	0,49	210	1367	36	0,15	0,59	350	2630	68	0,28	0,59	490	3610
80	17,5	13	0,05	0,48	210	1504	33	0,12	0,50	350	2895	65	0,22	0,54	490	3973
100	14,0	--	---	---	---	---	29	0,09	0,47	350	3118	55	0,16	0,50	490	4280

i	n2 (v/min)	TRV 63					TRV 75					TRV 90				
		Mn2 (Nm)	P (kW)	$\eta$	F1 (N)	F2 (N)	Mn2 (Nm)	P (kW)	$\eta$	F1 (N)	F2 (N)	Mn2 (Nm)	P (kW)	$\eta$	F1 (N)	F2 (N)
7,5	186,7	128	2,80	0,89	500	2359	185	4,10	0,88	700	2785	290	6,30	0,90	900	3081
10	140,0	130	2,20	0,87	571	2597	195	3,20	0,89	830	3065	310	5,10	0,89	1082	3391
15	93,3	140	1,60	0,86	615	2973	200	2,30	0,85	851	3509	360	4,10	0,86	1257	3882
20	70,0	135	1,20	0,82	667	3272	210	1,90	0,81	980	3862	355	3,10	0,84	1270	4273
25	56,0	130	1,00	0,76	700	3524	200	1,50	0,78	980	4160	340	2,40	0,83	1270	4603
30	46,7	160	1,10	0,71	700	3745	230	1,50	0,75	980	4421	410	2,60	0,77	1270	4891
40	35,0	145	0,76	0,70	700	4122	220	1,10	0,73	980	4865	360	1,80	0,73	1270	5383
50	28,0	135	0,60	0,66	700	4440	210	0,89	0,69	980	5241	340	1,40	0,71	1270	5799
60	23,3	130	0,51	0,62	700	4719	200	0,75	0,65	980	5569	320	1,10	0,71	1270	6163
80	17,5	122	0,39	0,57	700	5193	190	0,58	0,60	980	6130	285	0,83	0,63	1270	6783
100	14,0	118	0,34	0,51	700	5595	180	0,48	0,55	980	6603	270	0,67	0,59	1270	7306

i	n2 (v/min)	TRV 110					TRV 130					TRV 150				
		Mn2 (Nm)	P (kW)	$\eta$	F1 (N)	F2 (N)	Mn2 (Nm)	P (kW)	$\eta$	F1 (N)	F2 (N)	Mn2 (Nm)	P (kW)	$\eta$	F1 (N)	F2 (N)
7,5	186,7	552	12,00	0,90	1200	3893	750	16,10	0,91	1500	5092	1200	25,80	0,91	1950	6962
10	140,0	598	9,80	0,89	1463	4285	820	13,50	0,89	1845	5605	1240	20,20	0,90	2267	7663
15	93,3	656	7,50	0,85	1604	4905	920	10,30	0,87	2070	6416	1250	13,90	0,88	2285	8771
20	70,0	644	5,60	0,84	1700	5399	910	7,80	0,86	2100	7062	1300	11,10	0,86	2674	9654
25	56,0	679	4,70	0,85	1700	5816	930	6,50	0,84	2100	7607	1200	8,40	0,84	2800	10400
30	46,7	725	4,50	0,79	1700	6181	1040	6,40	0,79	2100	8084	1200	7,10	0,83	2800	11051
40	35,0	702	3,30	0,78	1700	6803	1050	4,90	0,79	2100	8897	1550	7,30	0,78	2800	12163
50	28,0	660	2,60	0,74	1700	7328	980	3,80	0,76	2100	9584	1400	5,40	0,76	2800	13103
60	23,3	616	2,10	0,72	1700	7787	900	3,10	0,71	2100	10185	1260	2,20	0,73	2800	13924
80	17,5	515	1,40	0,67	1700	8571	840	2,30	0,67	2100	11210	1150	3,10	0,68	2800	15325
100	14,0	487	1,10	0,64	1700	9232	740	1,70	0,64	2100	12076	1000	2,30	0,64	2800	16508



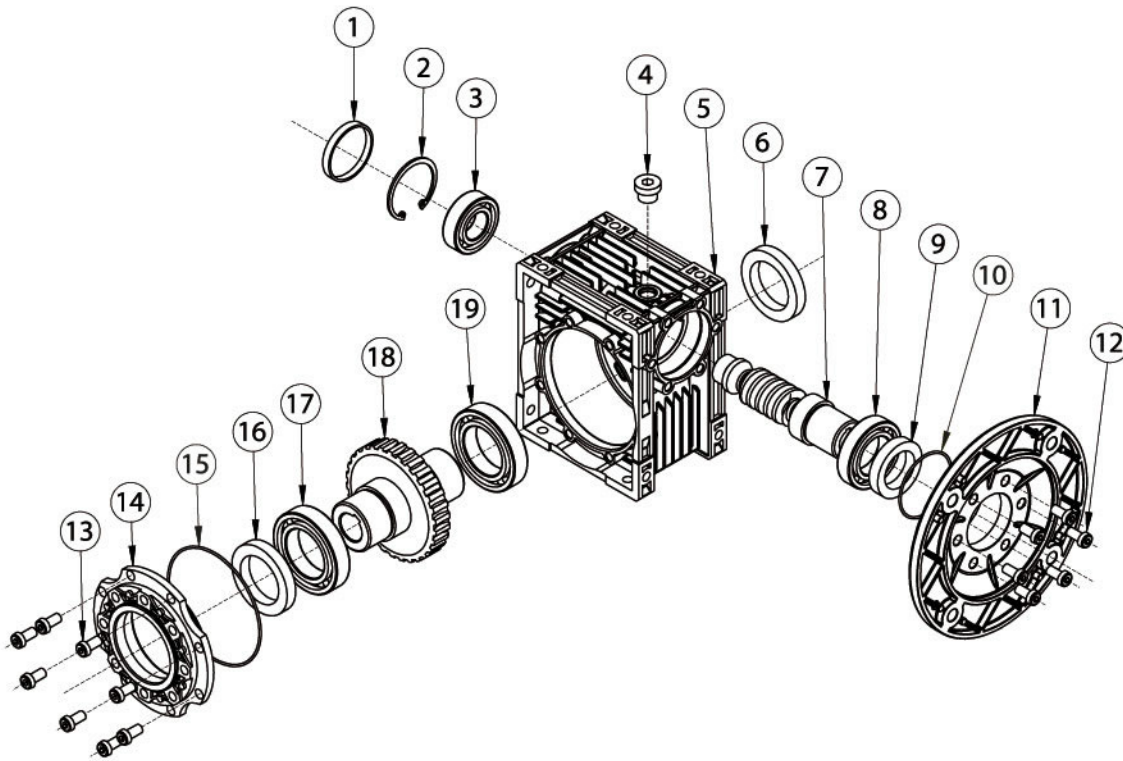

Item	Descripción
1	Tapa de sello
2	Seeger
3	Rod. lado opuesto
4	Tapón de aceite
5	Carcasa
6	Sello
7	Sinfin
8	Rod. lado brida entrada
9	Sello
10	O´ring
11	Brida lado entrada
12	Bulones brida entrada
13	Bulones tapa salida
14	Tapa lado salida
15	O´ring
16	Sello
17	Rod. lado brida salida
18	Corona
19	Rod. lado opuesto brida salida

Formas constructivas típicas

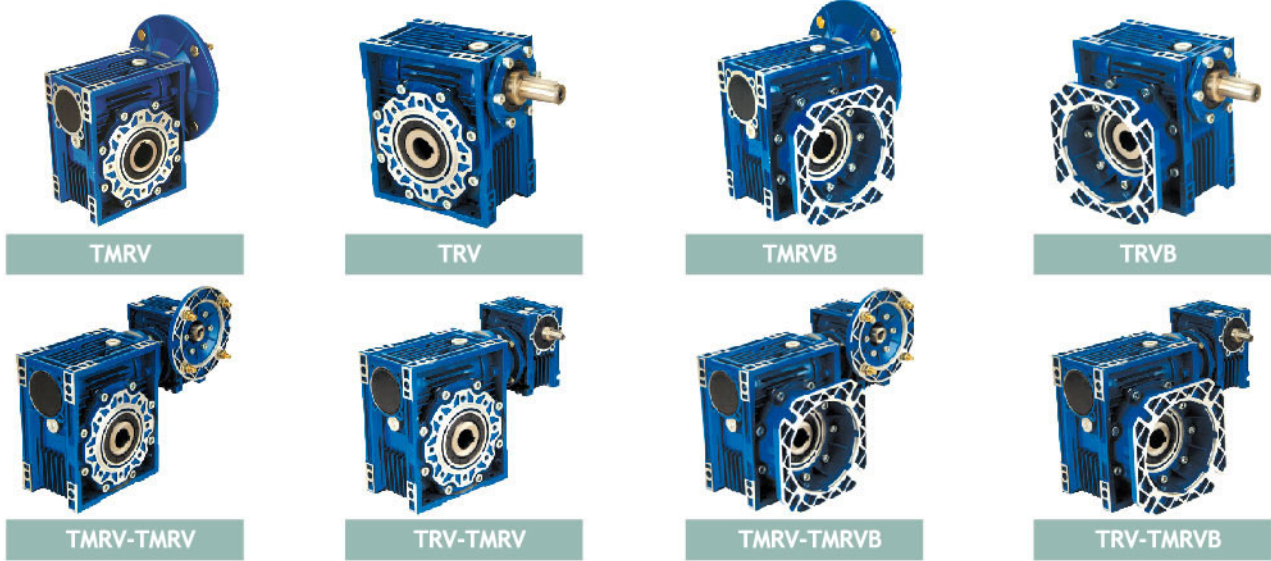

Tipo ISO VG	Aceites minerales			Aceites sintéticos Poli-Alfa-Olefina (PAO)			Aceites sintéticos Poli-Glicol (PG)			
	220	320	460	150	220	320	150	220	320	460
Temp. amb. [°C]	-5° ÷ 25°	0° ÷ 35°	10° ÷ 45°	-10° ÷ 25°	-5° ÷ 35°	0° ÷ 50°	-10° ÷ 25°	-5° ÷ 35°	0° ÷ 50°	10° ÷ 60°
SHELL	OMALA S2 G 220	OMALA S2 G 320	OMALA S2 G 460	OMALA S4 GX 150	OMALA S4 GX 220	OMALA S4 GX 320	OMALA S4 WE 150	OMALA S4 WE 220	OMALA S4 WE 320	OMALA S4 WE 460



Tekmatic S.A.

Pje. Cuba 751 - (1870) - Piñeyro - Avellaneda - Buenos Aires - Argentina

Tel.: +54 11 4222 5040/41/42 - Fax: +54 11 4201 2478

info@tekmatic.com.ar - www.tekmatic.com.ar